

Slimdrive SL

Slimdrive SL - FR

Automatic sliding door drive
with an overall height of 70 mm
SL-FR suitable for escape routes

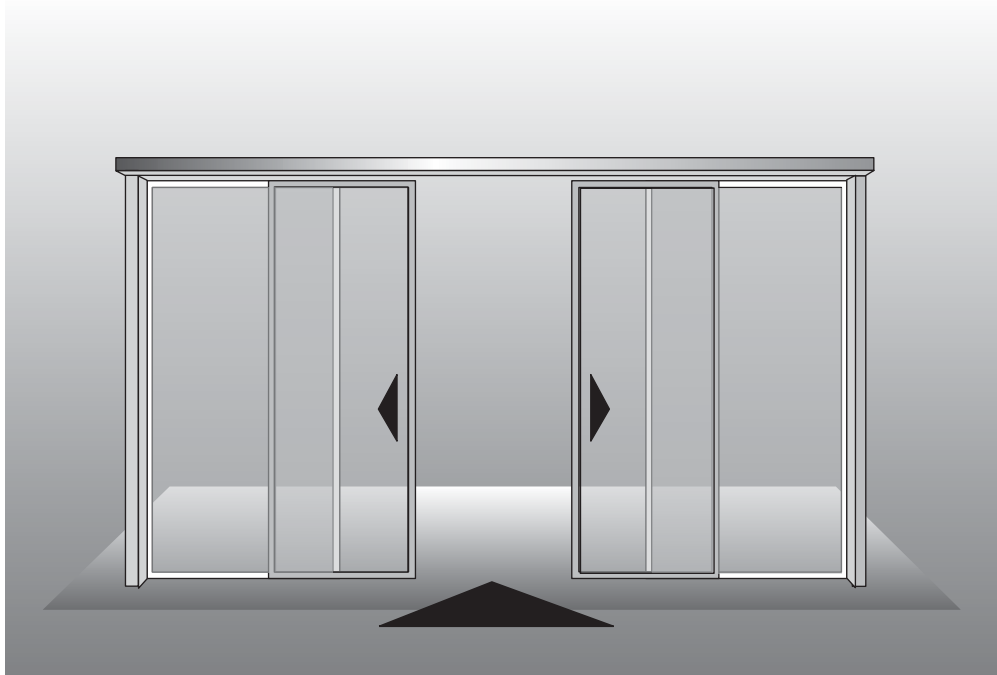

Planning document





Contents

Areas of application	4
Product features	5
System description	6
Safety functions	11
Components and profiles	12
Installation variations	13
Horizontal and vertical cross sections	18
Calculation of the overall length of the complete system	22
Calculation of glass dimensions for sliding leaf	22
Function description	23
Control elements / actuation devices	25
Draught lobbies	26
Wiring diagram Slimdrive SL, SL-FR (complete)	27
Statement from the manufacturer	28
Mark approval certificate	30

Areas of application

GEZE sliding door systems are used as automatic doors with horizontally sliding door leaves in low and high usage areas.

Slimdrive SL: The aesthetically designed sliding door system, single- or double-leaf, with an extremely low overall height of only 7 cm.

Slimdrive SL-FR: Developed especially for installation in escape and rescue routes where safety is of paramount importance.

- Office buildings
- Public buildings
- Chemists' premises
- Banks
- Hotels and restaurants
- Administration buildings
- Hospitals
- Care homes for the elderly or disabled
- Airports and railway stations
- Car show rooms
- Industrial buildings
- Draught lobbies

Due to the low overall height it is particularly well suited for:

- Integration in post/rail facades
- Modernisation
- Refurbishment
- Retro-fit installation into existing facades

Product features

Slimdrive SL or SL-FR: for architects, planners, clients and operators

- The extremely low overall height of the drive
 - imparts elegance
 - makes the drive disappear behind the facade thus emphasising aesthetics and transparency
 - offers large clear opening and passage heights
 - fits into any existing window and facade profile without difficulty
 - allows more natural light to enter creating bright and friendly entrances
 - requires no increased transom depths or wider spanning profiles
- Frameless leaves open up new possibilities for your aesthetic design ideas (GEZE I.G.G.)
- High-quality materials and the latest in control technology ensure high performance in your designated area of application
- A fully enclosed running profile improves the low-noise properties and extends the life of the product.
- TÜV type tested
- For escape routes

Slimdrive SL or SL-FR: for fabricators and partners

- Small number of profiles and modular construction
 - allow fast production of all customer-specific opening widths
 - reduces the storage costs
 - allow pre-assembly of the mechanic drive components
 - reduces installation times on site
- Economical retrofitting into existing facades or metal structures is possible due to low overall height

Slimdrive SL-FR: for the use on escape and rescue routes

- Dual-motor technology with maintenance-free motors
- The Slimdrive SL-FR has been approved for the use in escape and rescue routes in accordance with the guidelines for automatic sliding doors in escape routes (AutSchR) In addition to this, the sliding door drive has been tested in accordance with prEN 12650-1/2 and DIN V 18650-1/2 (2003).

System description

- System consisting of an all-aluminium construction, suitable for internal and external doors.

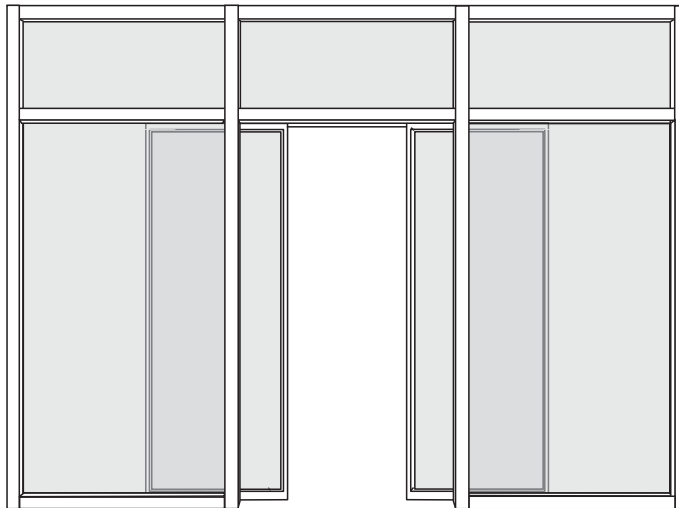

Available as type SL or SL-FR

- single-leaf, left-hand or right-hand closing
(with or without over panel)

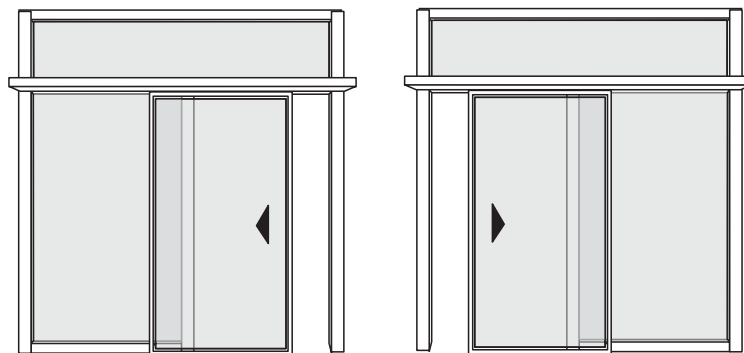

- double-leaf
(with or without over panel)



Types of door leaves

- Slim-framed profile system for ISO (insulating glass), ESG (toughened safety glass) and VSG (laminated glass)
- Frameless doors of insulating glass (GEZE-IGG)
- Doors of timber, UPVC/frame doors

Dimensions / Weights

Door leaf weight:		Single-leaf: up to 120 kgs Double-leaf: up to 2 x 120 kgs
Opening width:	Slimdrive SL	Single-leaf: 700 - 2000 mm Double-leaf: 900 - 3000 mm
	Slimdrive SL-FR	Single-leaf: 1000 - 2000 mm Double-leaf: 1000 - 3000 mm
Door leaf height:		max. approx. 2900 mm
Leaf ratio	Recommended by GEZE	1:3
(width and height)	max. leaf ratio	1:4
	(leaf ratio > 1:4 on request)	

Hint:

- The opening width and clear passage height stated above are standard measures. Special measures upon request.
- If the maximum opening width is combined with a large clear passage height, keep in mind that the maximum leaf weight must not exceed 120 kg. (standard ISO profile system = approx. 30 kg per m² leaf weight).
- For outdoor installations with an opening width of more than 2000 mm a continuous floor guide is recommended.

Drive

- Minimum space requirement: 70 mm high, 189 mm deep
- Extruded cover profiles in all RAL colours and most metal finishes
- Maintenance-free DC motor

Opening speed:	up to 0.7 m/s per leaf
Closing speed:	up to 0.4 m/s per leaf
- Extremely quiet, enclosed running gear
- Power transmission via toothed belts
- Leaf weight distributed evenly by two double rollers in precision bearings in the track profile
- Integrated double pole mains switch

Only Slimdrive SL-FR:

- Duplicate processing system by means of dual-motor technology/accumulator in connection with a redundant control
- Lockable programme switch
The programme switch may only be operated by authorized persons. For that reason a key-operated switch is absolutely necessary. The operating mode selected must be clearly identifiable.
- Self-monitoring movement detector (redundance)
The functionality must be controlled constantly. If an error is indicated the door moves into the open position (repair required).
- Information for the locking of emergency exit doors (mode of operation „NIGHT“):
Automatic sliding doors for the use on escape routes may be locked, unless these doors are not required as emergency exit doors for this specific period of time. This is normally the case if there are no more people in the building or if another escape route is indicated.

Control

- Fully digital control via 16 Bit high-performance microprocessor
- All adjustments of the system as well as the indication of the function, fault and maintenance parameters via programme switch
- Modes of operation: automatic, permanently open, shop-closing time (one-way) night
- The reduced opening width (winter opening) is infinitely variable in the self-learning mode; for the version Slimdrive SL-FR the prescribed minimum escape width (min. 30%) must be taken into consideration
- Different hold-open times for summer operation, winter operation and key-operated operation
- Display of statistical data as well as error indication via programme switch (number of opening movements, service interval)
- Self-learning door control
- Hold-open time can be automatically adapted to access frequency
- Connection to fire alarm system
- Electromechanical locking with optional alarm contact for alarm systems
- Opening and closing speeds are individually adjustable
- Error indication of safety sensors
- Error indication radar movement detector

Technical features

- Mains connection: 230 VAC; +6%/-10%; 50/60 Hz
- Power consumption max. 300 VA

Control elements

- only type-tested movement detectors must be connected in escape direction, apart from that all actuation elements can be connected, e.g.:
 - Radar movement detector where detection is independent of temperature
 - Infrared motion detectors
 - Light curtain
 - Buttons/switches
 - Key-operated switch
 - Code card reader

Options

For version Slimdrive SL and SL-FR

- Connection to fire alarm system via permanent potential-free contact, causing the doors to open regardless of their position.
- Link to burglar alarm will make doors close. Doors can lock if required.
- Chemists' late night opening setting. (Door opens to 200 mm and then locks.)
- Tamper contact for external key-operated switch
- Fault warning
- Standard locking
- Rod-locking (for double leaf version only)
- Bottom locking

For version Slimdrive SL (not permitted for SL-FR)

- Draught lobby or interlocking function can be controlled with only 1 programme switch for 2 installations
- Fixed panel safeguarding via sensors
- Emergency locking
- Switching over to other modes of operation by means of timer (SL on request)

Safety functions

- Closing force limited to <math><150\text{ N}</math>
- Opening force limited to <math><150\text{ N}</math>
- Safety sensor with self-testing function (safety photoelectric barrier or light curtain)
- Automatic reversing function with adjustable reversing pressure. The door opens automatically, if it meets an obstacle during closure (adjustable reversing pressure)
- Anti-Lock in opening direction
- Manual emergency unlocking (standard) with unlocking pin, electric emergency unlocking (option)
- Battery pack to open and close the door in the case of power failure (no permanent operation)
- Integrated mains switch

For Slimdrive SL-FR the following will apply in addition:

- Automatic opening of the door from the mode of operation "AUT" and "Shop Closing" in the case of failure or emergency owing to a dual-motor technology in connection with a battery pack.

Components and profiles

Modular construction system in aluminium structure

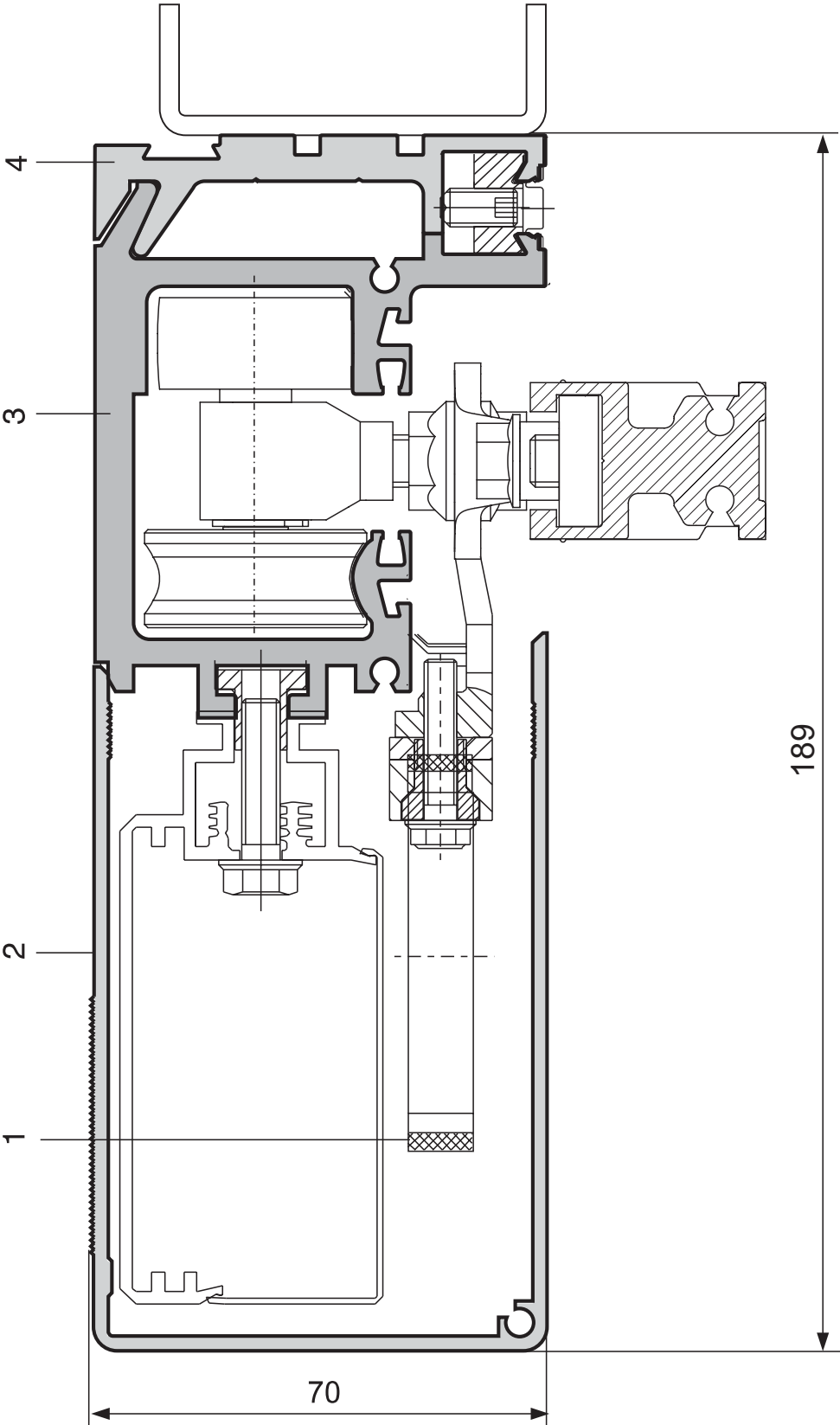

The profiles 2, 3 and 5 extend over the full length of the drive.

- 1. Toothed belt
- 2. Cover
- 3. Track with brush
- 4. Reception profile

Installation variations

If the building is used by persons requiring a certain degree of protection in accordance with the building law, further protective measures than those mentioned below may become necessary.

■ Installation into lintel without side element, double-leaf

- without protective door leaf

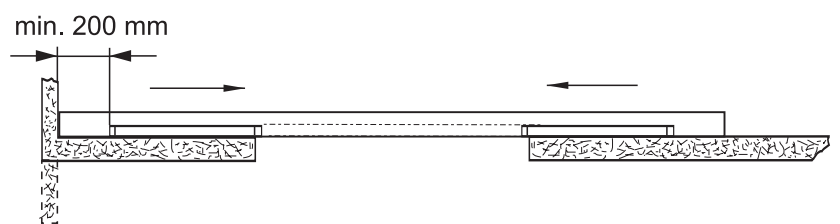

- with protective door leaf

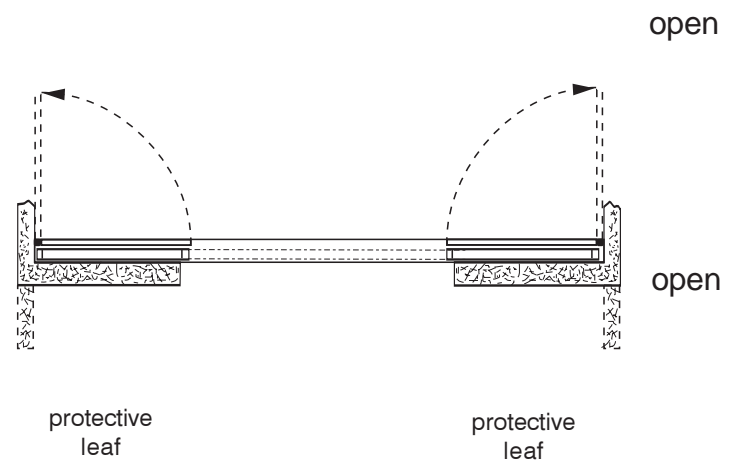

■ **Mounting to facade construction, double-leaf**

- with protection leaf

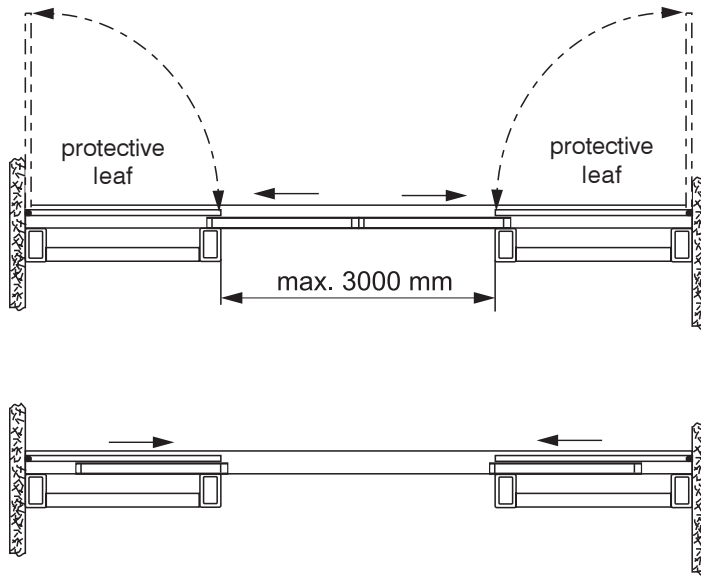

■ **Installation into facade construction, double-leaf**

- with safety leaf to prevent crushing

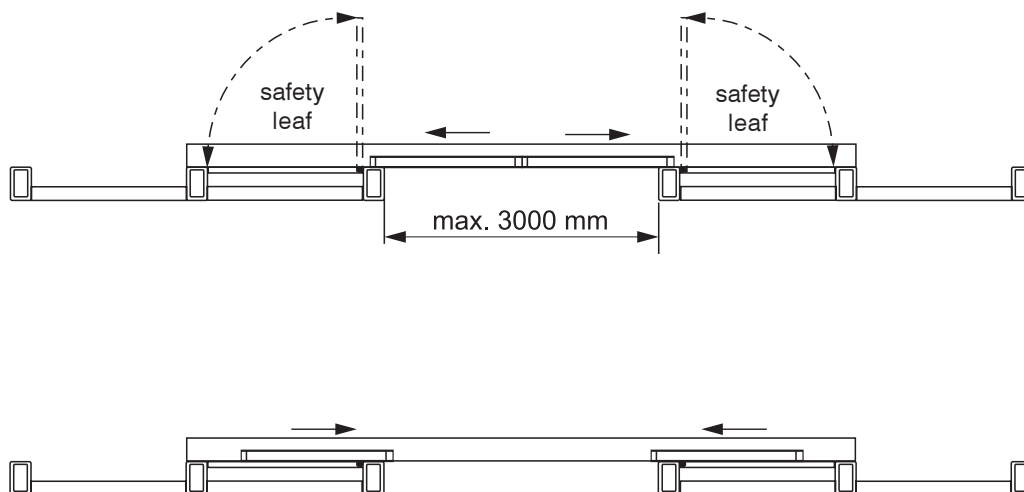

Mounting Slimdrive SL, SL-FR to post-rail structure

The following diagrams will only apply, if double-leaf drives are fixed to 4 posts or single-leaf drives are fixed to 3 posts.

Double-leaf

max. door leaf weight 2 x 120 kg
 max. ratio of leaf height/leaf width = 1:4
 calculation based on a leaf weight of 30 kg/m²

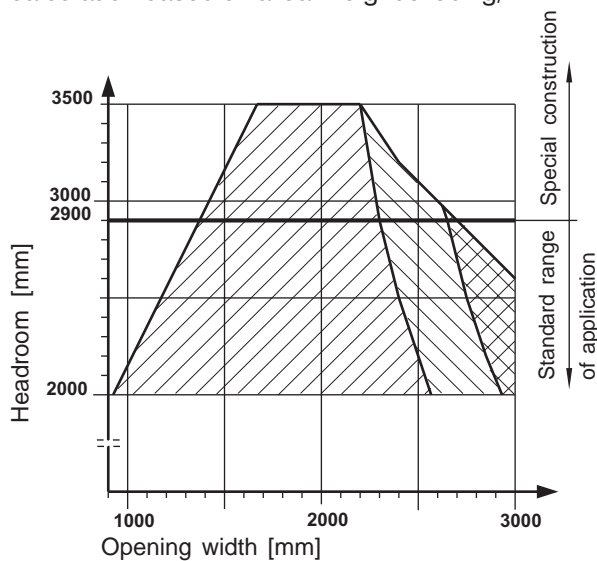

	Standard range of application
Profile:	
	Extended range of application with reinforced rail (steel tube) within the passage area (prov. by customer)
Profile:	
	Range of application with additional ceiling suspension
Profile:	

Single-leaf

max. door leaf weight 2 x 120 kg
 max. ratio of leaf height/leaf width = 1:4
 calculation based on a leaf weight of 30 kg/m²

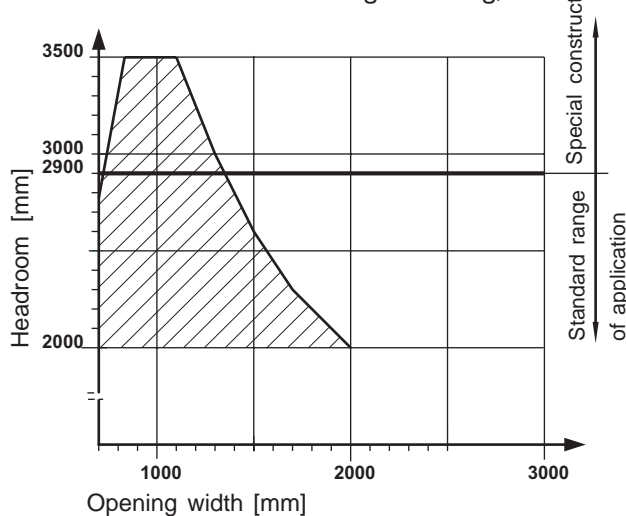

The potential opening width is reduced by 15 % if a shoot bolt lock is used.

■ **Mounting to self-supporting beam with and without fanlight**

- Self-supporting, double-leaf, side element width $L = (B-LD) / 2$
 - max. opening width = 2000 mm
 - max. Overall length = 4500 mm
 - max. height incl. fanlight = 3000 mm

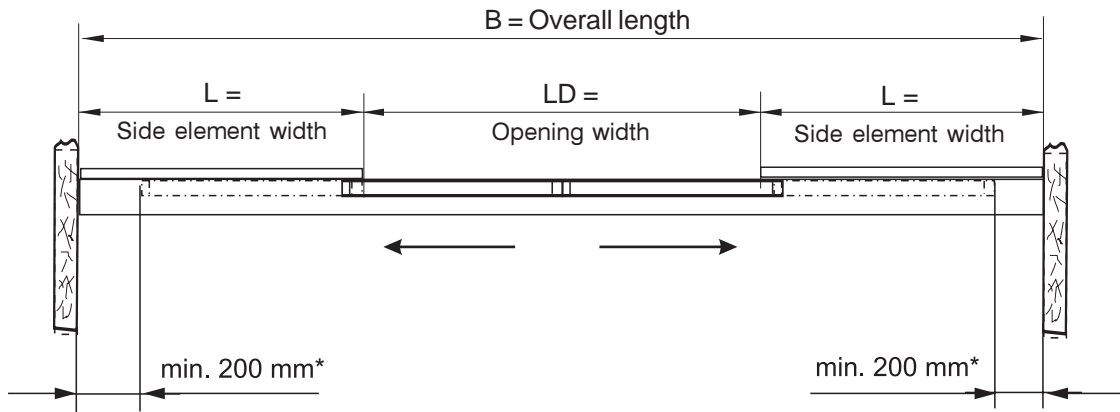

* an alternative safeguarding is possible

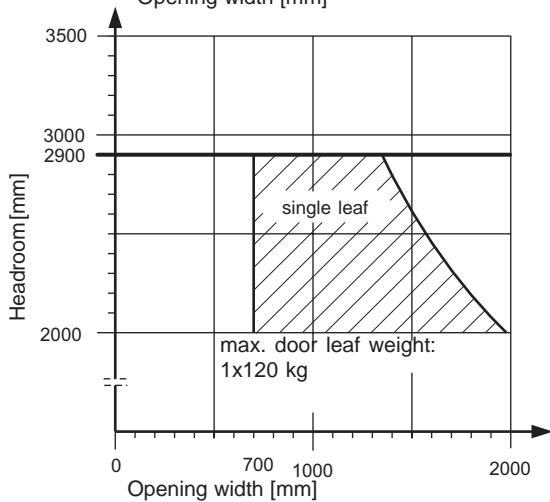
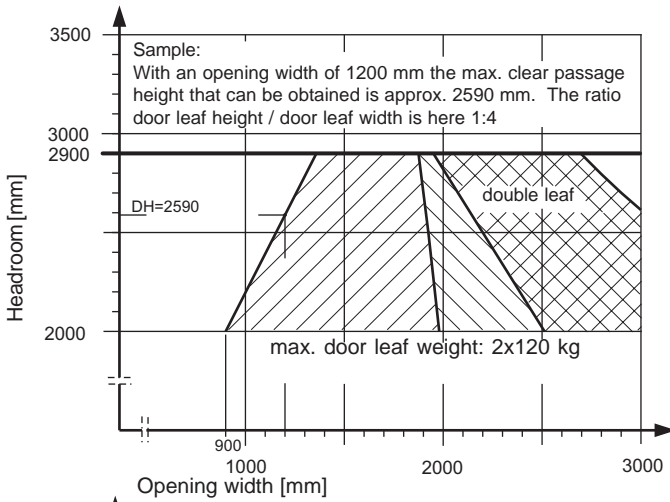

	Standard range of application: single carrier
Profile:	
	Additional range of application: double carrier
Profile:	
	Single carrier, carrier and track additionally suspended from the ceiling
Profile:	provided by client

Horizontal and vertical cross sections

■ ISO-profile system for facade constructions

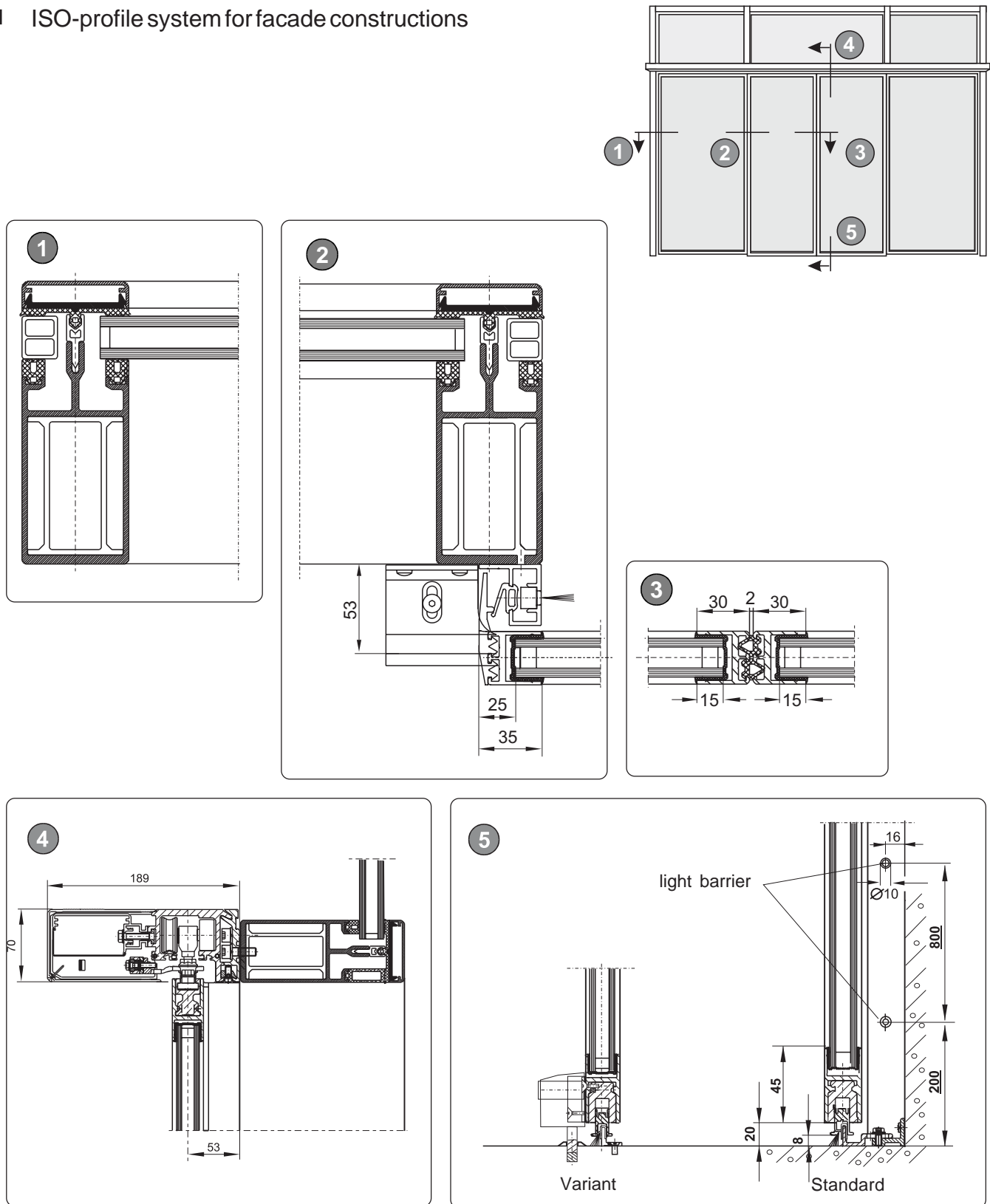

Hint:

A shoot bolt lock can be used for the ISO profile system. In this case the elevation width of the profiles at the main closing edge is 2 x 50 mm (instead of 2 x 30 mm)

■ Integrated all-glass system (GEZE-IGG)

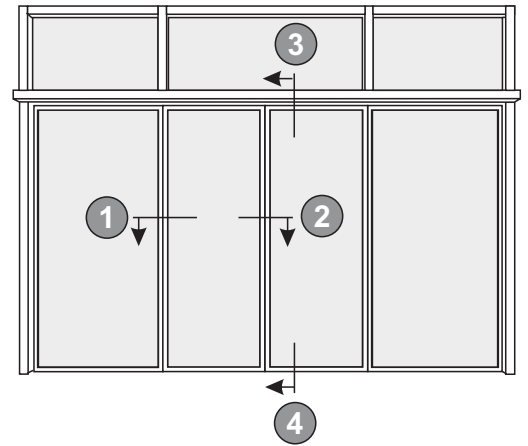
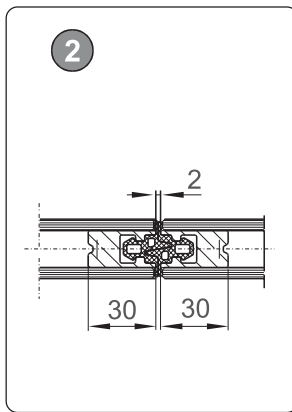
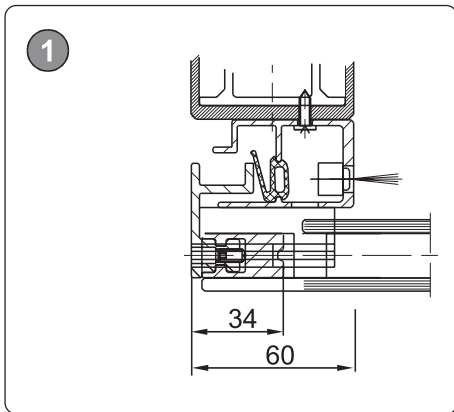

With I.G.G. sliding leaves, two types for posts with the projection width 50 or 60 mm are available

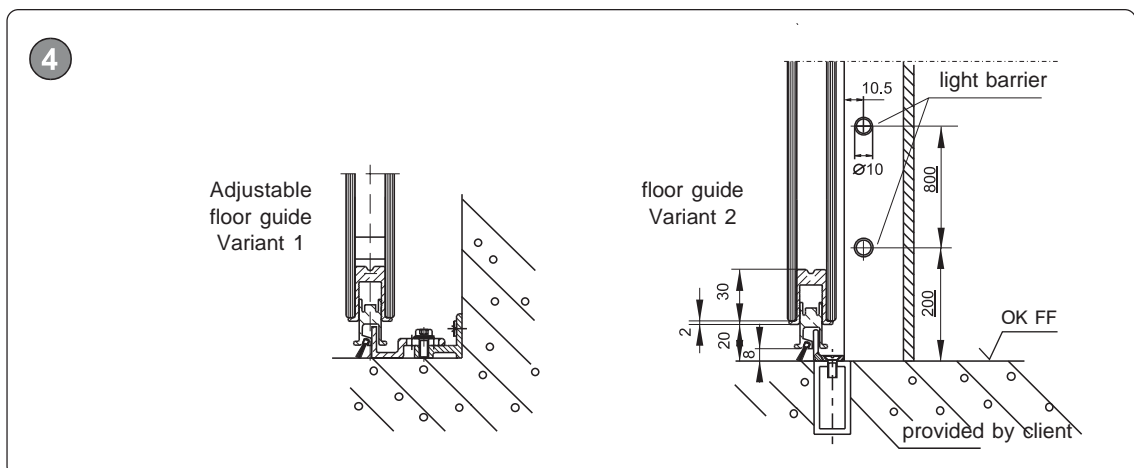
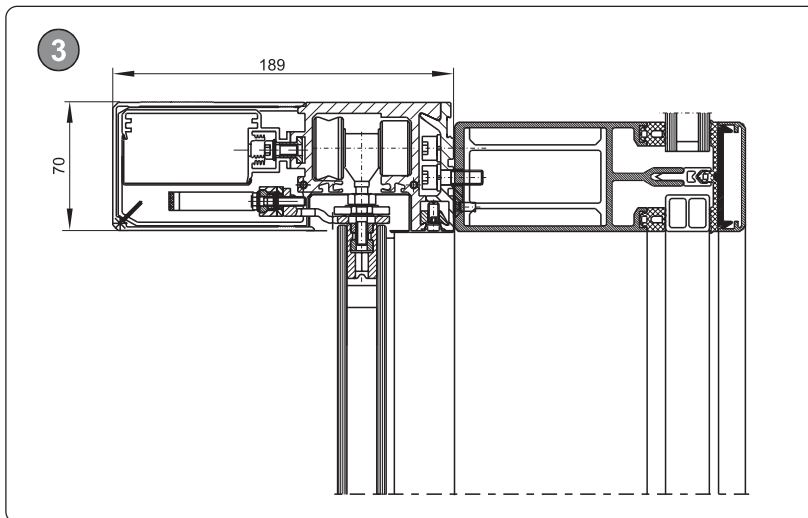

■ ISO profile system with side panels- wall mounting (=lintel mounting)

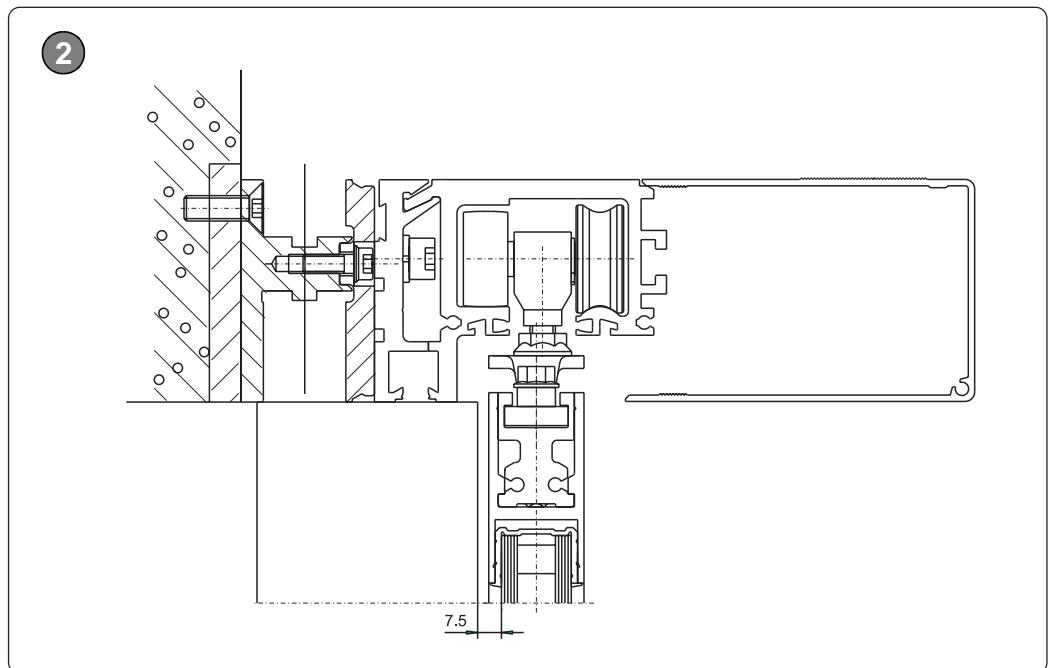
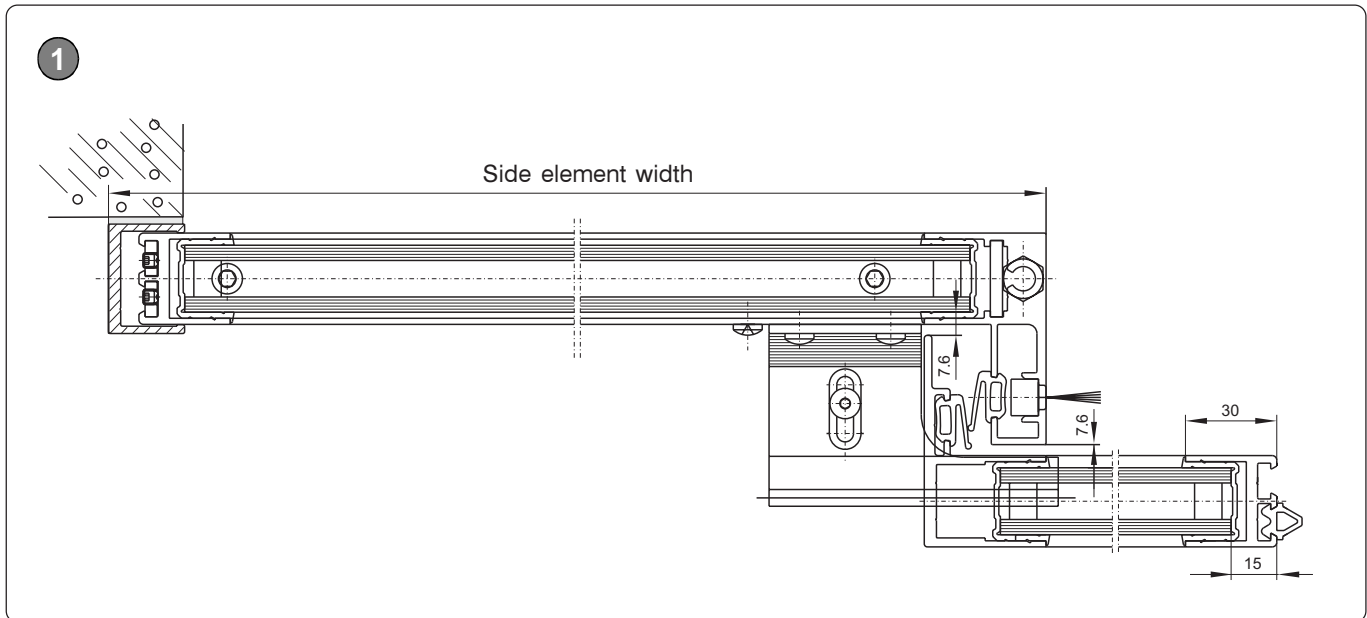
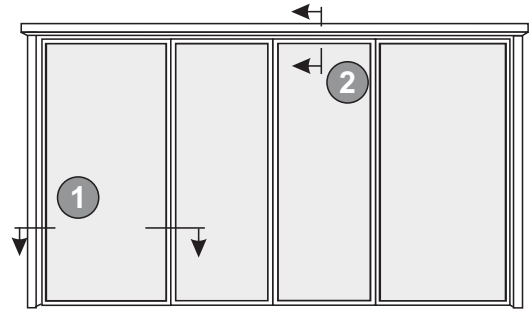

■ ISO profile system with side panels – self-supporting mounting

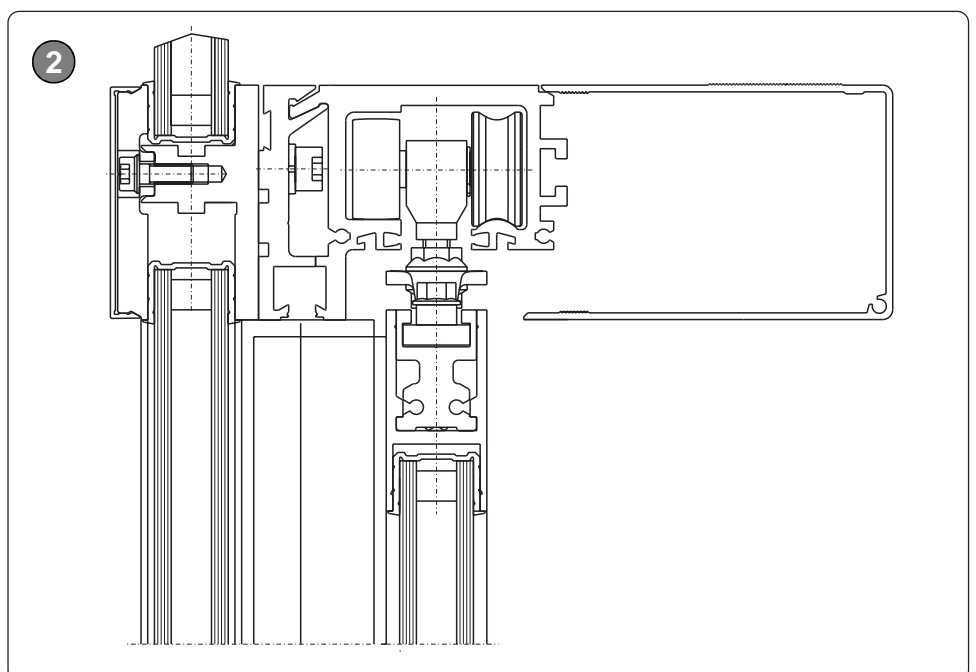
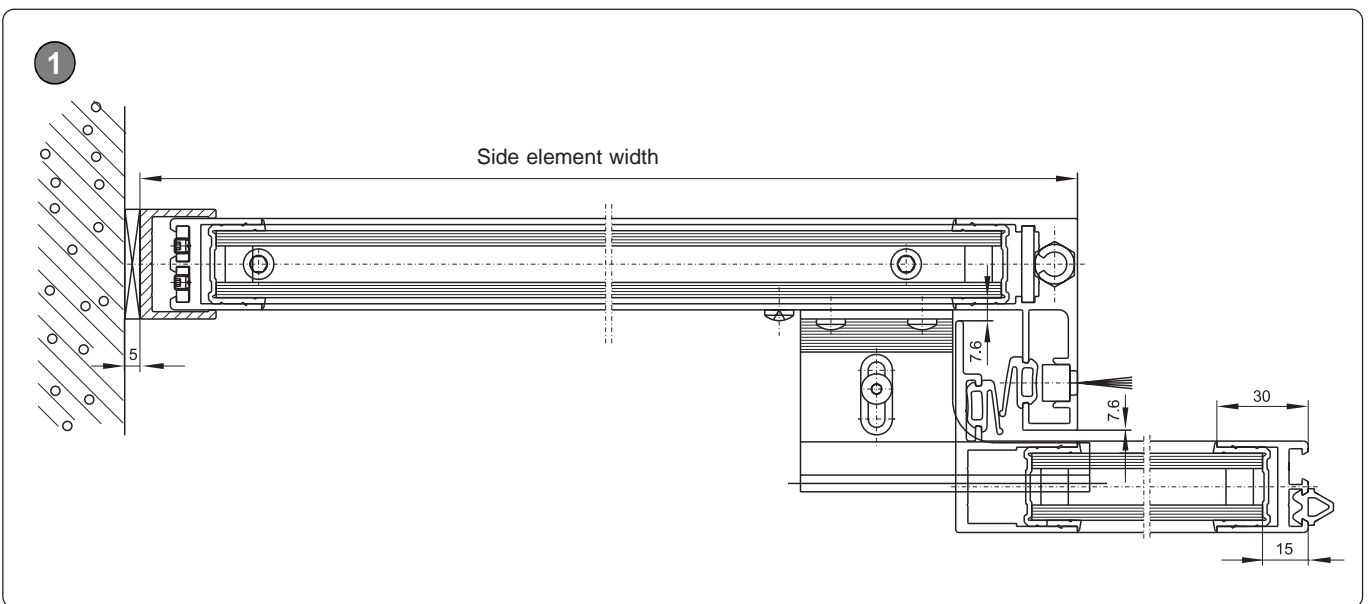
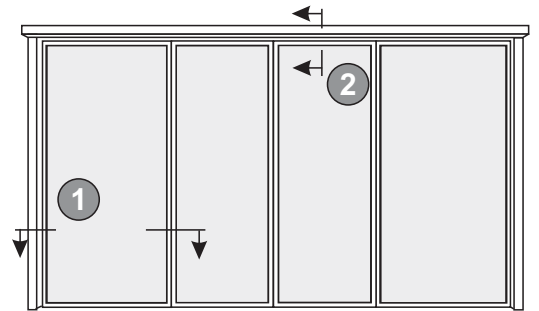

Calculation of the overall length of the complete system *)

	Slimdrive SL	Slimdrive SL-FR
double-leaf	OW 900 -1000 B = OW + 1100	OW 900 -1000 B = OW + 1100
	OW 1000 - 3000 B = 2 x OW + 100	OW 1000 - 3000 B = 2 x OW + 100
single-leaf	OW 700 - 2000 B = 2 x OW + 50	OW 700 - 800 B = OW + 850
		OW 800 - 2000 B = 2 x OW + 50

*) Min. overall length with ISO glass profile system

Hint:

Opening widths of sliding doors on escape routes smaller than 1000 mm are only admissible in special cases. The minimum opening widths have to comply with the requirements of the building regulations.

Calculation of glass dimensions for sliding leaf (ISO glass profile system)

Width	1-leaf	Glass width = OW
	2-leaf	Glass width = OW / 2*
Height	1 or 2-leaf	Glass height = DH - 107 [mm]

B = overall length of the complete system [mm]

DH = headroom

OW = opening width

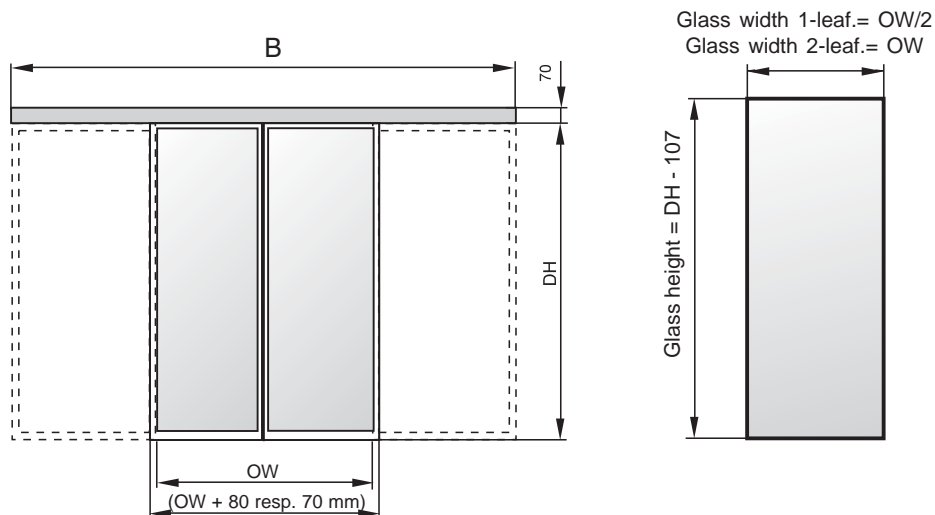

*in combinations with the shoot bolt lock the glass width = OW/2-20 [mm]

Function description

Display programme switch and key-operated reset switch

Slimdrive SL and SL-FR uses either a flush mounted or surface mounted programme switch with 7 segment display and membrane keypad. An additional key operated switch is mandatory for SL-FR type.

The display programme switch is used to select the mode of operation (see below) and to view error messages.

It is also used to programme and service the system.

Dimensions: width x height = 81 x 81 (mm)
for the installation in standard flush-mounted
box (Ø 60 x 42 deep)

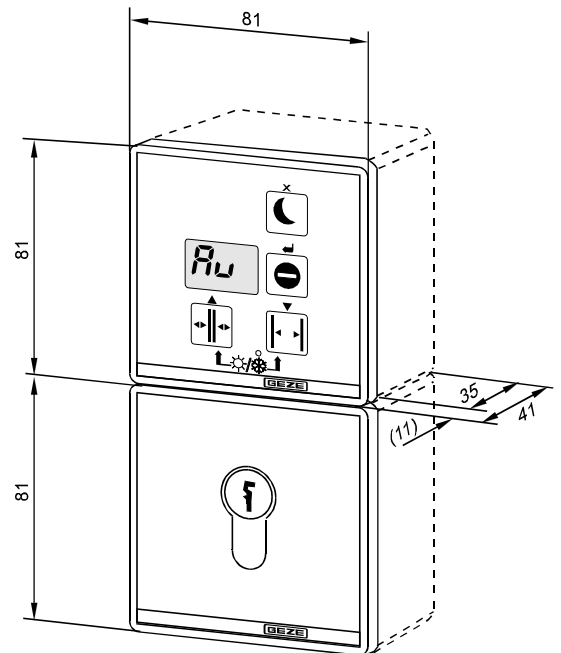

The following functions may be programmed via the programme switch:



Permanently open

The door moves into the OPEN position and remains open. Movement detectors or opening pushbuttons are not active.



Night (Option):

The movement detectors are inactive, the door closes. Optional: the door leaves lock electro-magnetically to prevent unauthorised access.



Shop closing time:

The door opens and closes only, if someone is leaving. The exterior movement detector is not active, the interior (one-way): movement detector is active.



Automatic operation:

The door opens as soon as it receives a signal from the movement detector or push buttons and closes again after a pre-set time. Photoelectric barriers scan the area the leaves are travelling. If a person stays within the doorway, the light barriers are interrupted and the door does not close.



Reduced opening width:

The settings determined in the learning mode can be activated or deactivated.



Key-operated

The programme switch can be locked using a key-operated switch (required for SL-FR)

■ Opening width

Maximum opening width:

The door travels to its maximum opening width when signalled or while set to the permanently open position.

Reduced opening width:

The door opens partially, even when set to automatic operation, permanently open, and to shop closing time position.

This means a reduced exchange of heat between the heated interior and cold air outside during the winter months. The opening width is infinitely variable by manually positioning the door in the learning mode. Please observe the minimum escape route width prescribed for version SL-FR

■ Hold open time

Describes the period of time in which the sliding doors are kept open before they close automatically. It may be adjusted freely from 0 to 60 seconds. Different hold-open times can be set for summer operation, winter operation and key-operated switch operation.

■ The hold-open time can be adapted to the access frequency

The hold-open time is automatically extended when the door opens and closes frequently and cannot close completely in between openings. (can be activated)

The hold-open time returns to its pre-set time as soon as the door closes completely once again.

■ Power failure:

In the case of power failure the Slimdrive SL offers the following functions: either select "STOP" or the door is driven by a battery pack and runs to the "OPEN" or "CLOSED" position and remains in this position. **Type SL-FR** will always move into the open position.

Control elements / actuation devices

Only approved radar movement detectors are permitted in the direction of the emergency exit.

- Radar movement detectors are activated by any kind of movement within the detection zone. The movement causes a delayed reflection of the beam transmitted by the radar unit. This shifted echo is measured, analysed and passed on in the form of an opening signal.
- Active infra-red movement detector are activated by people and objects based on the principle of short wave infra-red reflection. This provides a very precisely adjustable detection zone. It only analyses light transmitted by itself which means a very low level of interference. The opening signal is not only triggered by people and animals, but also by shopping trollies, hospital beds etc.
(Not allowed for escape routes).
- Passive infra-red movement detectors are activated by changes in temperature in conjunction with movement which makes them suitable for recognising people. A shopping trolley would not be detected due to the lack of heat emission.
(Not allowed for escape routes).
- Switch, key-operated switch, etc.
- Remote controls

Please notice:

Radar or infra-red movement detectors have to be protected from rain, snow and sun by e.g. a customer provided roof.

Locking the door, leaving / entering the building

How to pass the locked door?

The programme switch is set to night-setting. The door is closed and locked mechanically.

- Leaving the room:
Operating the manual unlocking device opens the door. It will close and lock automatically after you have left the room.
- Entering the room:
The door may be opened with a key-operated switch or any other electronic actuation device. The door is unlocked and opens.
After you have left the room, the door closes and locks automatically.
Now you can select the desired operation mode using the programme switch.

Draught lobbies

Draught lobbies are used to avoid draught and to reduce the exchange of heat. Ideally, only one door should be open.

Direction-sensing radar movement detectors only trigger the door if people approach door. Therefore the door closes sooner after the person has entered. A separate programme switch is required for each FR-door.

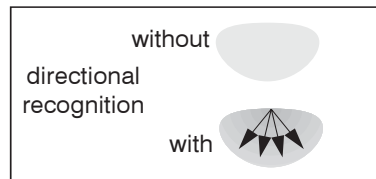

Examples for possible combinations:

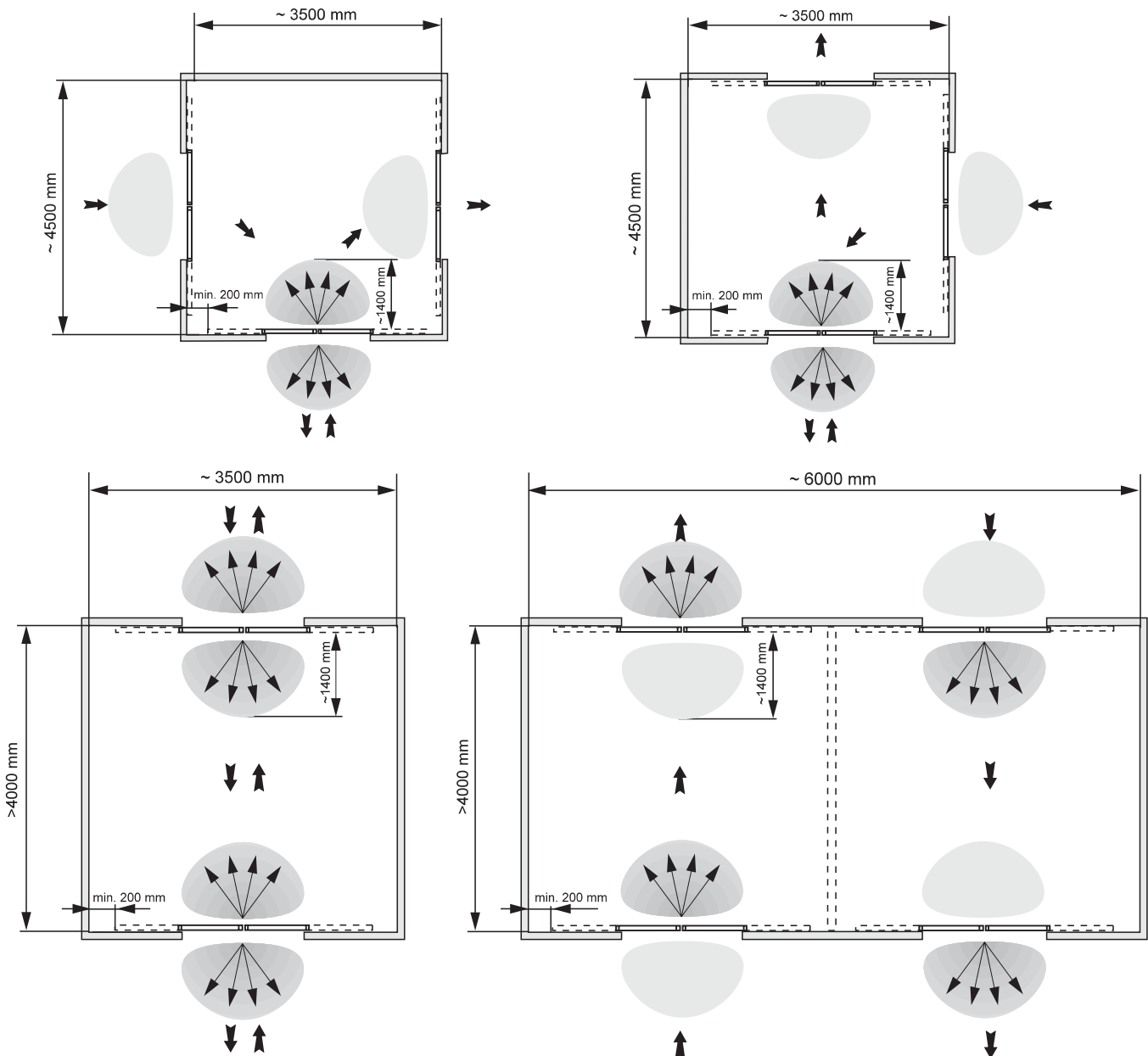

Wiring diagram Slimdrive SL, SL-FR

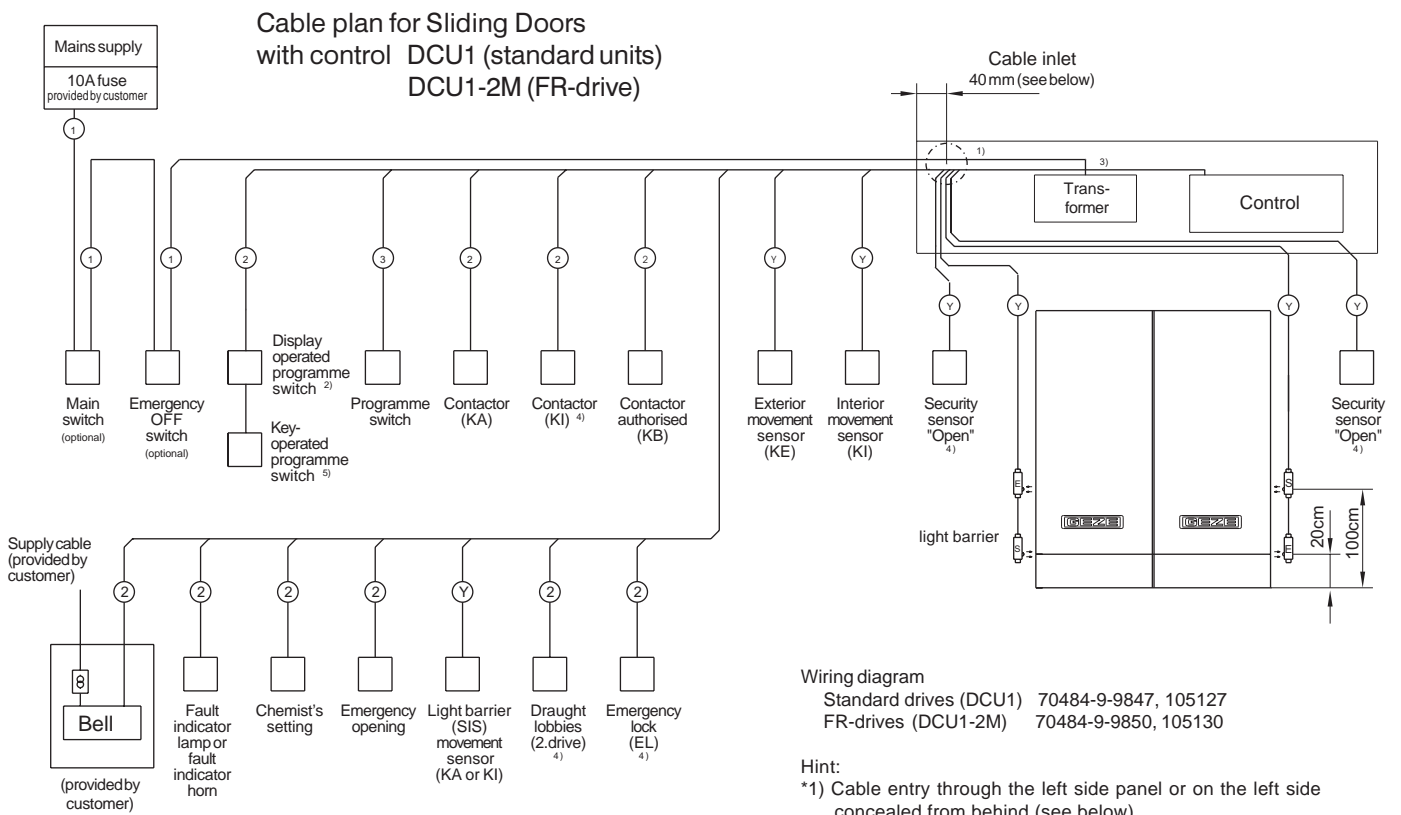

Wiring diagram
 Standard drives (DCU1) 70484-9-9847, 105127
 FR-drives (DCU1-2M) 70484-9-9850, 105130

- Hint:
- *1) Cable entry through the left side panel or on the left side concealed from behind (see below)
 - *2) Cable length max. 100 m
 - *3) Allow signal cable to protrude min. 5 m from the wall, supply mains min. 2 m
 - *4) Does not apply for DCU 1-2M
 - *5) Required for DCU1-2M

Wire cross sections

- ① = NYM-J 3x1,5 mm²
- ② = I-Y(ST)Y 2x2x0,6 mm
- ③ = I-Y (ST)Y 3x2x0,6 mm
- Y = included in GEZE package with GEZE products

Note

Cable installation to VDE 0100

Cable installation, connection and commissioning should be performed by authorised technicians only.

Cable laying for Slimdrive drives

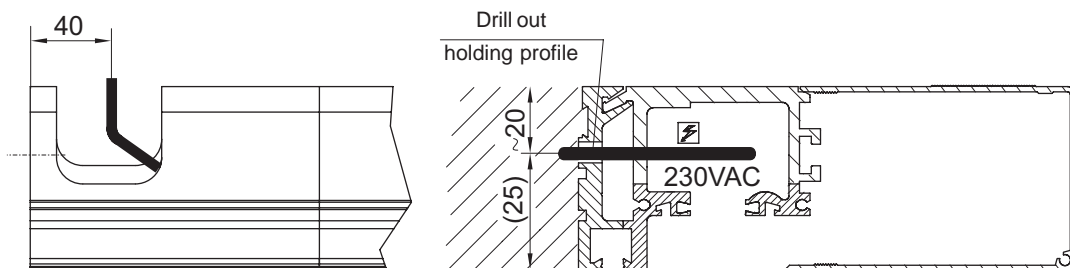

This drawing shows the actual state of product development at the date of the drawing or the revision date. No claims or damages in any form can be made against GEZE as a result of the interpretation of this drawing. This drawing remains the property of GEZE and is made available to third parties only for the duration of contractual obligations.
 All rights connected with this drawing remain in possession of GEZE. This drawing may not be copied or handed over to third parties without the express consent of GEZE.

Statement from the manufacturer

persuant to Appendix II Bof the Maschine Directive 89/392/EEC version 98/37/EC

Manufacturer: GEZE GmbH
Reinhold-Vöster-Straße 21-29
71229 Leonberg

Product designation: GEZE Slimdrive SL Drive

Statement :

This drive is developed, designed and produced in accordance with the Maschine Directive 89/392/EEC, version 98/37/EC and the Construction Products Directive 89/106/EEC, version 93/68/EC solely by GEZE GmbH and is not intended for use on its own.

Additional applicable EU directives:

- EMC Directive 89/336/EEC, version 93/31/EEC
- Low-Voltage Directive 73/23/EEC, version 93/68/EEC
- R & TTE-Directive 1999/9/EC

Applied harmonized standards :

- EN 292 Parts 1 and 2
- EN 50081-1
- EN 50082-2
- EN 60335-1
- EN 60950
- prEN 12650-1
- prEN 12650-2

Applied nationales standards and technical specifications :

- ZH 1/494
- DIN V VDE 0801

Documentation operating instructions:

The delivery documentation, the statement from the manufacturer and the operating instructions are included with the drive.

Note:

Commisioning the described drive is not permissible until it has been determined that the door system which will accept this drive complies with the standards of the Maschine Directive and the Construction Products Directive.



Hermann Alber
Managing Director

Leonberg, 4 th. Sept 2003

Statement from the manufacturer

persuant to Appendix II Bof the Maschine Directive 89/392/EEC version 98/37/EC

Manufacturer: GEZE GmbH
Reinhold-Vöster-Straße 21-29
71229 Leonberg

Product designation: GEZE Slimdrive SL - FR Drive

Statement :

This drive is developed, designed and produced in accordance with the Maschine Directive 89/392/EEC, version 98/37/EC and the Construction Products Directive 89/106/EEC, version 93/68/EC solely by GEZE GmbH and is not intended for use on its own.

Additional applicable EU directives:

- EMC Directive 89/336/EEC, version 93/31/EEC
- Low-Voltage Directive 73/23/EEC, version 93/68/EEC
- R & TTE-Directive 1999/9/EC

Applied harmonized standards :

- EN 292 Parts 1 and 2
- EN 50081-1
- EN 50082-2
- EN 60335-1
- EN 60950
- prEN 12650-1
- prEN 12650-2

Applied nationales standards and technical specifications :

- ZH 1/494
- AutSchR
- DIN V VDE 0801

Documentation operating instructions:

The delivery documentation, the statement from the manufacturer and the operating instructions are included with the drive.

Note:

Commisioning the described drive is not permissible until it has been determined that the door system which will accept this drive complies with the standards of the Maschine Directive and the Construction Products Directive.



Hermann Alber
Managing Director

Leonberg, 4 th. Sept 2003



TÜV Certificate No. P-2096/04 (English Issue)

(valid only in association with the terms overleaf)

Holder of the certificate: GEZE GmbH
Reinhold-Vöster-Straße 21-29, 71229 Leonberg

Site of Manufacture: GEZE GmbH
Reinhold-Vöster-Straße 21-29, 71229 Leonberg

Type Approval Mark:

valid until
2008-12-31



Product: Automatic in-line sliding door
Model: Slimdrive SL

Testing based
on the following:

- pr EN 12650-1/2: 2002 / DIN V 18650-1/2: 2003
Locks and metal fittings - automatic door systems
 - ZH 1/494: 1989-04; Guideline for power-operated windows, doors and gates
 - DIN EN 60 335-1: 2003-07
Safety of electrical equipment intended for domestic and similar use
Part 1: General requirements
 - DIN EN 60 950: 2003-03
Safety of information technology equipment
 - BGV A 1 (General regulations) as of 2000-03-01, §§ 28 and 29
 - Regulation for workshops (ArbStättV) as of 2002-09-27
§ 10 in conjunction with: ASR 10/1, 10/5, 10/6
§ 11 in conjunction with: ASR 11/1-5
- All standards, regulations or guidelines named in the above-mentioned basic documents must also be considered valid.

Result of testing:

The Test Centre for Building Industry Products of the TÜV Thüringen e.V., a Test Centre recognised together with its associated laboratories by the German Institute for Building Technique Berlin as PÜZ (Test and Monitoring Centre) under the name THU 08, hereby confirms that:

The results of the type approval test show that in compliance with the terms laid down in the Type Approval Certificate P-2096/04, the specifications made in the bases for testing are met by the product as a whole. Permission is hereby given to use the Test Mark illustrated above, in accordance with the contractual terms printed overleaf.

Zella-Mehlis, 2004-02-06

TÜV Thüringen e.V. (Association for Technical Inspection)
Test Centre for Building Products

Graduate Engineer (FH) Reichelt
Manager of the Test Centre





TÜV Certificate No. P-2018/03 (English Issue)

(valid only in association with the terms overleaf)

Holder of the certificate: GEZE GmbH
Reinhold-Vöster-Straße 21-29, 71229 Leonberg

Site of Manufacture: GEZE GmbH
Reinhold-Vöster-Straße 21-29, 71229 Leonberg

Type Approval Mark:

valid until
2007-12-31



Product: Automatic in-line sliding door, for the use on escape and rescue routes
Model: Slimdrive SL-FR 2M, single-leaf / double-leaf

- Testing based on the following:
- Guideline for automatic sliding doors on escape and emergency routes (AutSchR) (Information of the DIBt, Dec 1998 edition)
 - pr EN 12650-1/2: 2002 / DIN V 18650-1/2: 2003
Locks and metal fittings - automatic door systems
 - ZH 1/494: 1989-04; Guideline for power-operated windows, doors and gates
 - DIN EN 60 335-1: 1995-10
Safety of electrical equipment intended for domestic and similar use
Part 1: General requirements
 - DIN EN 60 950: 2001-12
Safety of information technology equipment
 - BGV A 1 (General regulations) as per 2000-03-01, §§ 28 and 29
 - Workplace Code (ArbStättV) as per 1996-12-04
(Guideline 89/654 EWG of 1989-11-30)
§ 10 in conjunction with: ASR 10/1, 10/5, 10/6
§ 11 in conjunction with: ASR 11/1-5
- All standards, regulations or guidelines named in the above-mentioned basic documents must also be considered valid.

Result of testing:

The Test Centre for Building Industry Products of the TÜV Thüringen e.V. a Test Centre recognised together with its associated laboratories by the German Institute for Building Technique Berlin as PÜZ (Test and Monitoring Centre) under the name THU 08, hereby confirms that:

> The type conforms to the regulations of Building Regulation List A, part 1, No. 6.18 for building industry products that are subject to general technical rules <

The results of the type approval test show that in compliance with the terms laid down in the Type Approval Certificate P-2018/03, the specifications made in the bases for testing are met by the product as a whole. Permission is hereby given to use the Test Mark illustrated above, in accordance with the contractual terms printed overleaf.

Zella-Mehlis, 2003-10-15

TÜV Thüringen e.V. (Association for Technical Inspection)
Test Centre for Building Products

Graduate Engineer (FH) Reichelt
Manager of the Test Centre



GEZE GmbH
P.O. Box 1363
71226 Leonberg
Germany
GEZE GmbH
Reinhold-Vöster-Str. 21-29
71229 Leonberg
Germany
Tel. +49 (0)7152 203-0
Fax +49 (0)7152 203-310

GEZE Online:
www.geze.com

GEZE Branches

Germany

GEZE GmbH
Niederlassung Nord/Ost
Bühningstr. 8
13086 Berlin (Weissensee)
Tel. +49 (0)30 47 89 90-0
Fax +49 (0)30 47 89 90-17
E-Mail: berlin.de@geze.com

GEZE GmbH

Niederlassung West
Nordsternstraße 65
45329 Essen
Tel. +49 (0)201 8 30 82-0
Fax +49 (0)201 8 30 82-20
E-Mail: essen.de@geze.com

GEZE GmbH

Niederlassung Mitte
Adenauerallee 2
61440 Oberursel
Tel. +49 (0)6171 6 36 10-0
Fax +49 (0)6171 6 36 10-1
E-Mail: frankfurt.de@geze.com

GEZE GmbH

Niederlassung Süd
Reinhold-Vöster-Straße 21-29
71229 Leonberg
Tel. +49 (0)7152 203-594
Fax +49 (0)7152 203-438
E-Mail: leonberg.de@geze.com

Subsidiaries

Germany

GEZE Sonderkonstruktionen GmbH

Planken 1
97944 Boxberg-Schweigern
Tel. +49 (0)7930 92 94-0
Fax +49 (0)7930 92 94-10
E-mail: sk.de@geze.com

GEZE SERVICE GmbH

Reinhold-Vöster-Str. 25
71229 Leonberg
Te. +49 (0) 7152- 92 33-0
Fax +49 (0) 7152- 92 33-60
E-Mail: info@geze-service.com

GEZE SERVICE GmbH

Niederlassung Berlin
Bühningstraße 8
13086 Berlin (Weissensee)
Tel. +49 (0) 30- 47 02 17 30
Fax +49 (0) 30- 47 02 17 33

Asia

GEZE Asia Pacific Ltd.

Unit 630, Level 6, Tower 2
Grand Central Plaza
138 Shatin Rural Committee Road
Shatin, New Territories
Hong Kong
Tel. +852 (0)23 75 73 82
Fax +852 (0)23 75 79 36
E-Mail: info@geze.com.hk

GEZE Industries (Tianjin) Co., Ltd.

Shuangchenzhong Road
Beichen Economic Development Area (BEDA)
Tianjin 300400, P.R. China
Tel. +86 (0)22 26 97 39 95-0
Fax +86 (0)22 26 97 27 02
E-Mail: geze@public1.tpt.tj.cn

GEZE Industries (Tianjin) Co., Ltd.

Branch Office Shanghai
Dynasty Business Center
Room 401-402
No. 457 WuRuMuQi North Road
200040 Shanghai, P.R. China
Tel. +86 (0)21 52 34 09-60/-61/-62
Fax +86 (0)21 52 34 09-63
E-Mail: gezesh@geze.com.cn

GEZE Industries (Tianjin) Co., Ltd.

Branch Office Guangzhou
Room 1113 Jie Tai Plaza
218-222 Zhong Shan Liu Road
510180 Guangzhou, P.R. China
Tel. +86 (0)20 81 32 07-02
Fax +86 (0)20 81 32 07-05
E-Mail: gezegz@public2.sta.net.cn

GEZE Industries (Tianjin) Co., Ltd.

Branch Office Beijing
The Grand Pacific Building
B Tower Room 201
8A, Guanghua Road
Chaoyang District
100026 Beijing, P.R. China
Tel. +86 (0)10 65 81 57-32/-42/-43
Fax +86 (0)10 65 81 57-33
E-Mail: gezebj@geze.com.cn

GEZE Asia Sales Ltd.

No. 88-1-408, East Road
Free Trade Zone of Tianjin Port
Tianjin, P.R. China
Tel. +86 (0)22-26 97 39 95-0
Fax +86 (0)22 26 97 27 02
E-mail: geze@public1.tpt.tj.cn

Middle East

U.A.E

GEZE Middle East
P.O. Box 17903
Jebel Ali Free Zone
Dubai, U.A.E.
Tel. +971 (0)4 88 33-112
Fax +971 (0)4 88 33-240
E-Mail: geze@emirates.net.ae

Europe

France

GEZE France S.A.R.L.
ZAC de l'Orme Rond
RN 19
77170 Servon
Tel. +33 (0)1 60 62 60-70
Fax +33 (0)1 60 62 60-71
E-mail: france.fr@geze.com

Great Britain

GEZE UK Ltd.
Blenheim Way
Fradley Park
Lichfield
Staffordshire, WS13 8SY
Tel. +44 (0)1543 44 30-00
Fax +44 (0)1543 44 30-01
E-Mail: info@geze-uk.com

Italy

GEZE Italia Srl
Via Giotto 4
20040 Cambiagio (Mi)
Tel. +39 02 95 06 95-11
Fax +39 02 95 06 95-33
E-Mail: italia.it@geze.it

GEZE Engineering Roma Srl

Via Lucrezia Romana 91
00178 Roma
Tel. +39 06 72 65 31-1
Fax +39 06 72 65 31-36
E-Mail: gezeroma@libero.it

GEZE Engineering Bari Srl

Via Treviso 58
70022 Altamura (Bari)
Tel. +39 080 3 11 52 19
Fax +39 080 3 16 45 61
E-Mail: gezebari@libero.it

Benelux

GEZE Benelux B.V.
Industrieterrein, Kapelbeemd,
Leemkuil 1,
5626 EA Eindhoven
Tel. +31 (0)40 2 62 90-80
Fax +31 (0)40 2 62 90-85
E-Mail: benelux.nl@geze.com

Austria

GEZE Austria GmbH
Mayrwiesstraße 12
5300 Hallwang b. Salzburg
Tel. +43 (0)662 66 31 42
Fax +43 (0)662 66 31 42-15
E-Mail: austria.at@geze.com

Poland

GEZE Polska Sp.z o.o.
ul. Annapol 3 (Zeran Park)
03-236 Warszawa
Tel. +48 (0)22 8 14 22 11
Fax +48 (0)22 6 14 25 40
E-mail: geze@geze.pl

Schweizerland

GEZE Schweiz AG
Bodenackerstr. 79
4657 Dulliken
Tel. +41 (0) 62 2 85 54-00
Fax +41 (0) 62 2 85 54-01
E-Mail: schweiz.ch@geze.com

Spain

GEZE Iberia S.R.L.
Pol. Ind.El Pla
C/ Comerc, 2-22, Nave 12
08980 Sant Feliu de Llobregat
(Barcelona)
Tel. +34 902 19 40-36
Fax +34 902 19 40-35
E-Mail: iberia.es@geze.com

Skandinavia

Sweden

GEZE Scandinavia AB
Mallsingan 10
Box 7060
18711 Täby
Tel. +46 (0)8 7 32 34-00
Fax +46 (0)8 7 32 34-99
E-Mail: sverige.se@geze.com

Norway

GEZE Scandinavia AB avd. Norge
Postboks 63
2081 Eidsvoll
Tel. +47 (0)639 5 72-00
Fax +47 (0)639 5 71-73
E-Mail: norge.se@geze.com

Finland

GEZE Finland
Branch office of GEZE Scandinavia AB
Postbox 20
158 71 Hollola
Tel. +385 (0)10 4 00 51-00
Fax +385 (0)10 4 00 51-20
E-Mail: finland.se@geze.com

Denmark

GEZE Denmark
Branch office of GEZE Scandinavia AB
Møllehusene 3, 3. th.
4000 Roskilde
Tel. +45 (0)46 32 33-24
Fax +45 (0)46 32 33-26
E-Mail: danmark.se@geze.com

Your attention is drawn to the product liability law defined liability to the manufacturer for this products which are contained in the main catalogue (product information, usage, misuses, product activity, product maintenance, the duty to inform and the duty to instruct). Non compliance with these conditions relieves the manufacturer from any liability.

GEZE Representative:

